

Nominal data

Type	4312 GM	
Nominal voltage	VDC	12
Nominal voltage range	VDC	6 .. 15
Speed	min ⁻¹	2300
Power input	W	3.1
Min. ambient temperature	°C	-20
Max. ambient temperature	°C	75
Air flow	m ³ /h	140
Sound power level	B	5.3
Sound pressure level	dB(A)	39

ml = Max. load · me = Max. efficiency · fa = Running at free air · cs = Customer specs · cu = Customer unit
Subject to alterations

4312 GM

DC axial compact fan

Technical features

Housing material	Fibreglass-reinforced plastic (PBT)
Impeller material	Fibreglass-reinforced plastic (PA)
Mass	0.220 kg
Dimensions	119 x 119 x 32 mm
Direction of air flow	Air exhaust over bars
Direction of rotation	Right, looking at rotor
Bearing	Sintec sleeve bearing
Lifetime L10 at 40 °C	70000 h
Lifetime L10 at maximum temperature	30000 h
Connection line	Single strands AWG 22, TR 64, bared and tin-plated.
Motor protection	Protected against reverse polarity and locking.
Locked-rotor protection	Blocking and overload protection
Approval	VDE, CSA, UL, CE
Option	Vario-Pro

4312 GM

DC axial compact fan

Product drawing

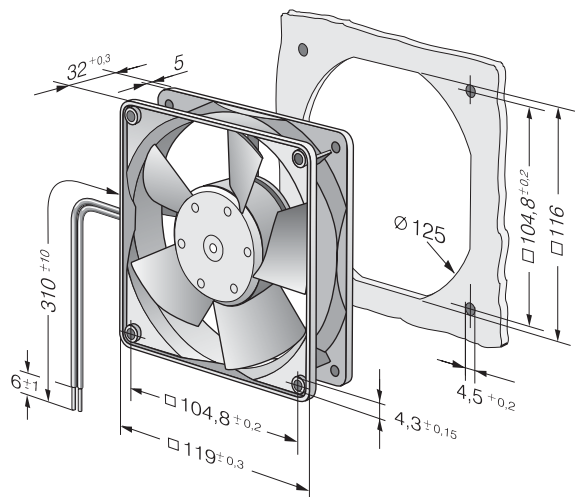

Charts: Air flow

